



MALKA OSŁONY MIKROFONOWE



K A T A L O G

MALKA OSŁONY MIKROFONOWE

- to rodzina produktów spełniających najwyższe wymagania stawiane w profesjonalnych zastosowaniach.

Parametry akustyczne naszych osłon uzyskane dzięki wyrefinowanej technologii produkcji stawiają nas na pozycji lidera.

Tworzymy z pasją, aby przełamywać bariery uznawane dotąd za niemożliwe do pokonania.

W naszej ofercie znajdują się osłony do większości typów mikrofonów, wykonane z najwyższej jakości surowców, zapewniających doskonałą ochronę przeciwwietrzną z jednoczesnym zachowaniem parametrów danego mikrofonu.

Standardowo osłony dostępne są w kolorach: czarnym, czerwonym, żółtym, zielonym, niebieskim, grafitowym i cielistym.

Jesteśmy w stanie zrealizować zamówienie na osłony do każdego mikrofonu, w dowolnym kolorze oraz wykonania nadruku firmowego.



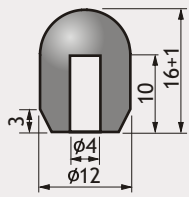

M - 1

AKG	CK-77, CK-97-0
SHURE	WBH 53(BETA 53)
SENNHEISER	ME 102, ME 104, ME 105

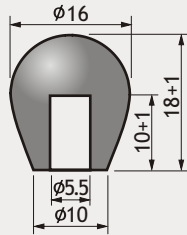

M - 2

AKG	C 417, C 407
SHURE	WL-50

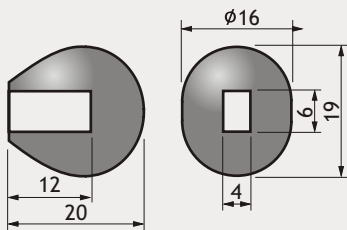

M - 3 studio

SHURE	WL 93
-------	-------

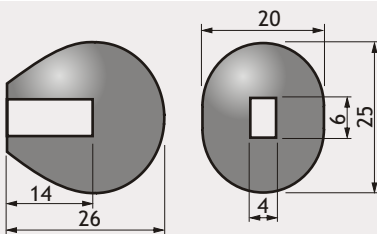

M - 3 plener

SHURE	WL 93
-------	-------

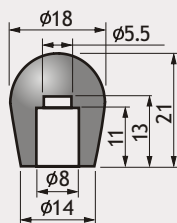

M - 4 studio

SENNHEISER	ME 102
z siatką	

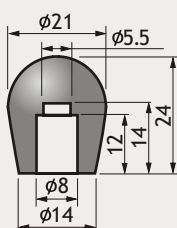

M - 4 plener

SENNHEISER	ME 102
z siatką	

OSLONY PODSTAWOWE – P

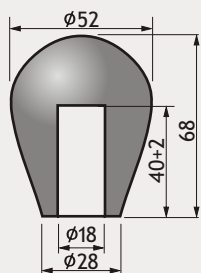

P - 5

AKG	D 160, C 430, C 391B
SHURE	PROLOGUE 16

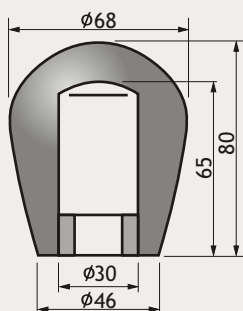

P - 6

AKG	C 100
SHURE	PROLOGUE 10
ELEKTROVOICE	COBALT C 04

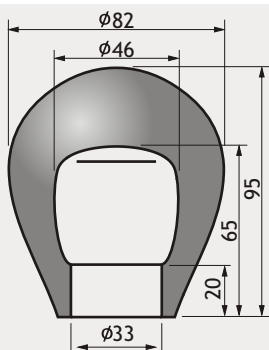

P - 7 plener

AKG	D 230, D 660, D 40, D 50, D 60
SHURE	SM 48, SM 58, PG 48, PG 58, BETA 58, C 606, C 607
BEHRINGER	XM 8500
SEKAKU	WR 101R
PEAVEY	PV-1

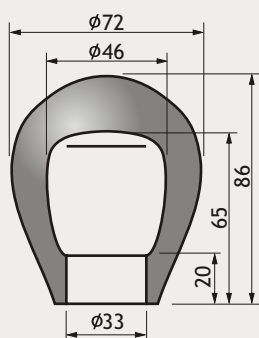

P - 7 studio

AKG	D 230, D 660, D 40, D 50, D 60
SHURE	SM 48, SM 58, PG 48, PG 58, BETA 58, C 606, C 607
BEHRINGER	XM 8500
SEKAKU	WR 101R
PEAVEY	PV-1

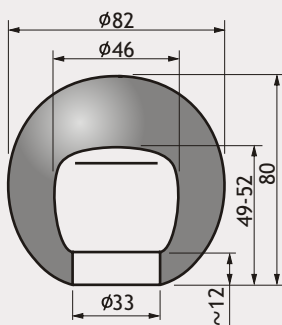

P - 8

AKG	D 230, D 660, D 40, D 50, D 60
SHURE	SM 48, SM 58, PG 48, PG 58, BETA 58, C 606, C 607
BEHRINGER	XM 8500
SEKAKU	WR 101R
PEAVEY	PV-1

OSŁONY PODSTAWOWE – P

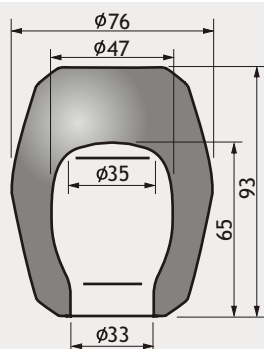

P - 9 plener

AKG	D 770
SHURE	PG 57, BG 2.1
SENNHEISER	e 825, e 835, e 845, e 855, MD-46, ME 3005
ELEKTROVOICE	RE-50, COBALT C 07

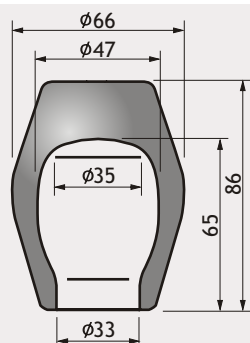

P - 9 studio

AKG	D 770
SHURE	PG 57, BG 2.1
SENNHEISER	e 825, e 835, e 845, e 855
ELEKTROVOICE	RE-50, COBALT C 07

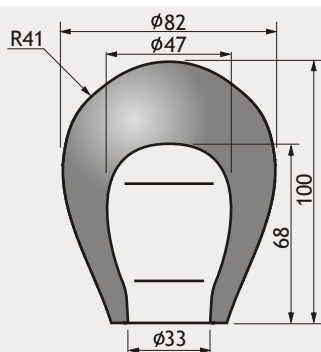

P - 10

AKG	D 880, D 3700, D 3800, C 5900
SHURE	ETV, EUT
SEKAKU	WR 101R

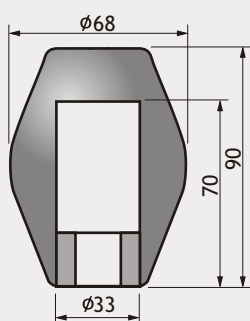

P - 11

AKG	D 190
SHURE	515SD

OSŁONY SPECJALNE - S

S - 1

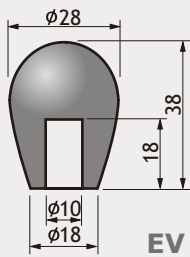

EV

S - 2

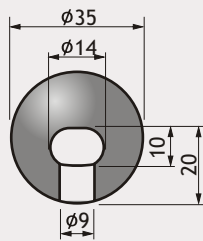

AKG	C 420, C 418, C 419, C 416, C 444
SHURE	SM 10A, WH 20

S - 3

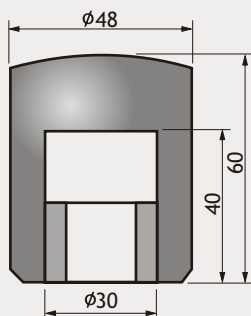

S - 4

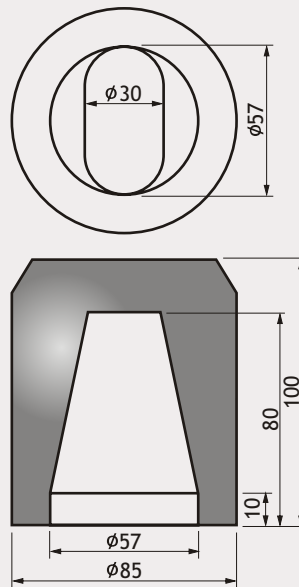

AKG	C 3000(B)
NEUMAN	TLM 103

OSŁONY NIETYPOWE - N

N - 1

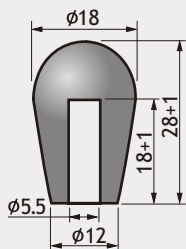

AKG	C 417
-----	-------

N - 2

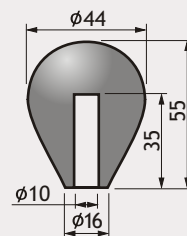

N - 3

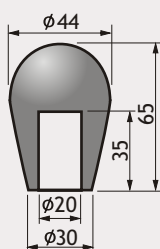

N - 4

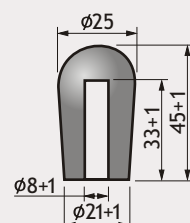

AKG	CK-55L
-----	--------

OSŁONY KIERUNKOWE - K

Oslony kierunkowe - wykonujemy do wszystkich typów mikrofonów

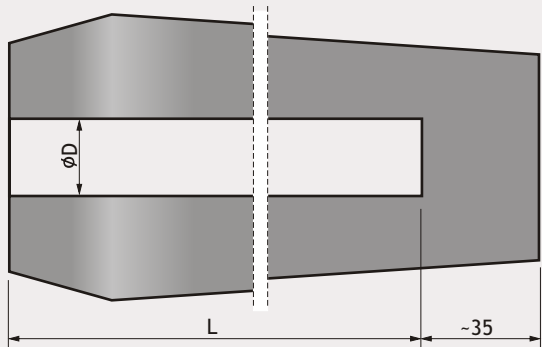

L - długość zależna od typu mikrofonu
D - wewnętrzna średnica otworu zależna od typu mikrofonu

normalne KN

AKG	C-100S, C-451, C-430, C-391, CK-98, C-480
SHURE	PROLOGUE 16A, PG 81
SENNHEISER	MKH 20, MKH 30, MKH 40, MKH 50, MKH 60, MKH 70, MKH 80, MKH 800, MKH 416, ME 62, ME 64, ME 66, ME 67

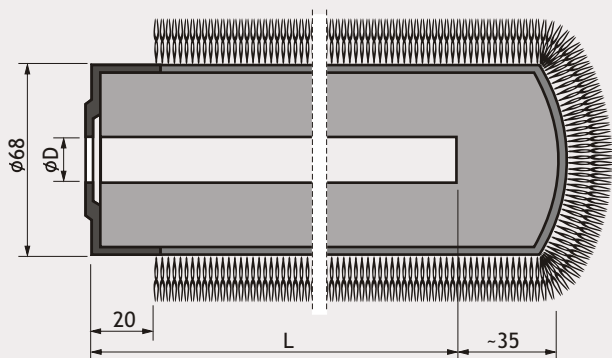

L - długość zależna od typu mikrofonu
D - wewnętrzna średnica otworu zależna od typu mikrofonu

futrzak KF

AKG	CK-98, C-568
SENNHEISER	MKH 20, MKH 30, MKH 40, MKH 50, MKH 60, MKH 70, MKH 80, MKH 800, MKH 416, ME 62, ME 64, ME 66, ME 67

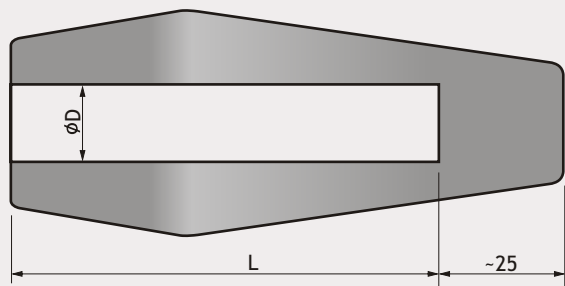

L - długość zależna od typu mikrofonu
D - wewnętrzna średnica otworu zależna od typu mikrofonu

do kamer KN

AKG	C-568
SENNHEISER	ME-66, MKH 50, MKH 416, MKH 418
PANASONIC	AJD 70, VSQ 1121



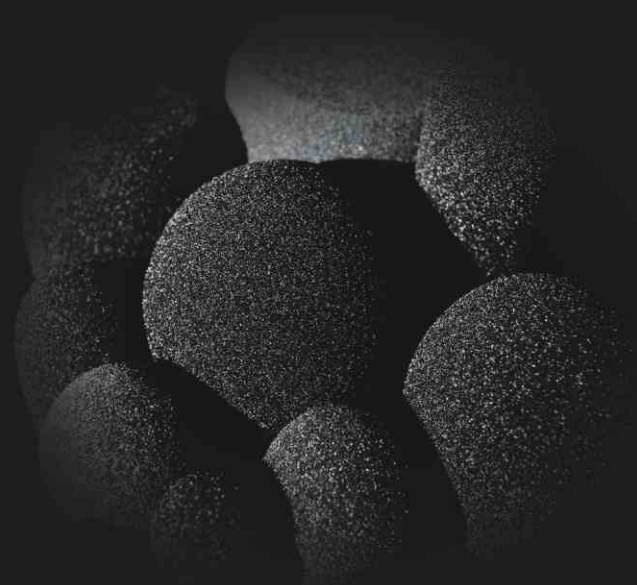

MALKA OSŁONY MIKROFONOWE

Malka - Osłony Mikrofonowe
ul. Wrocławska 134
58-306 Wałbrzych
tel./fax 74 66 42 373
www.malka-mikrofony.pl